

- GENERAL NOTES:**
- ALL CONSTRUCTION SHALL BE IN ACCORDANCE WITH THE LATEST CITY OF BRYAN/COLLEGE STATION STANDARD SPECIFICATIONS AND DETAILS FOR (WATER, SEWER, STREETS, DRAINAGE). ALL CONSTRUCTION SHALL BE COORDINATED WITH THE CITY ENGINEER'S OFFICE.
 - ALL UTILITY LINES (WATER, GAS, SANITARY SEWER, STORM SEWER, ETC.) SHOWN ARE TAKEN FROM BEST AVAILABLE RECORD INFORMATION BASED ON CONSTRUCTION UTILITY MAP DOCUMENTS OBTAINED FROM CITY & INDEPENDENT AGENCIES AND/OR AERIAL GROUND FIELD EVIDENCE. SHOWN POSITIONS MAY NOT REPRESENT AS-BUILT CONDITIONS.
 - THE CONTRACTOR SHALL BE RESPONSIBLE FOR VERIFYING THE EXACT LOCATION OF ALL EXISTING UNDERGROUND UTILITIES. NOTIFICATION OF THE UTILITY COMPANIES 48 HOURS IN ADVANCE OF CONSTRUCTION IS REQUIRED.
 GAS: (800) 344-8377
 AMOS ENERGY: (979) 774-2506
 SUDEN LINK COMMUNICATIONS: (979) 595-2429
 FRONTIER COMMUNICATIONS: (979) 821-4783
 WATER/SEWER CITY OF BRYAN: (979) 209-5900
 BTU: (979) 821-5700
 CITY OF BRYAN: (979) 209-5900
 - THE CONTRACTOR SHALL SETUP A PRE-CONSTRUCTION MEETING WITH BTU PRIOR TO THE START OF ELECTRICAL INFRASTRUCTURE CONSTRUCTION.
 - THE CONSTRUCTION SHALL COMPLY WITH OSHA STANDARD 29 CFR PART 1926 SUBPART P FOR TRENCH SAFETY REQUIREMENTS.
 - BUILDING SETBACK SHALL BE IN ACCORDANCE WITH THE CITY OF BRYAN LAND AND SITE DEVELOPMENT ORDINANCE.
 - PROPOSED SIGNS SHALL BE PERMITTED SEPARATELY IN ACCORDANCE WITH THE SIGN ORDINANCE.
 - IT IS THE RESPONSIBILITY OF THE CONTRACTOR TO USE WHATEVER MEANS NECESSARY TO MAINTAIN PROTECTION AND PREVENT SEDIMENT FROM LEAVING THE PROJECT SITE. THIS INCLUDES THE INSTALLATION OF A CONSTRUCTION EXIT AND SILT FENCE AS NECESSARY.
 - THE CONTRACTOR IS REQUIRED TO MAINTAIN THE TPDES GENERAL PERMIT NO. TXR 150000 REQUIREMENTS FOR CONSTRUCTION SITES.
 - ALL AREAS WHERE EXISTING VEGETATION AND GRASS COVER HAVE BEEN DISTURBED BY CONSTRUCTION SHALL BE RESEEDED WITH SEEDS OF HYDRATED GRASS AND MAINTAINED UNTIL GROWTH IS ESTABLISHED. IN DEVELOPED AREAS WHERE GRASS IS PRESENT, BOD SOIL WILL BE RECOVERED. BARE AREAS SHALL BE SEED OR SOODED WITHIN 14 CALENDAR DAYS OF LAST DISTURBANCE.
 - LANDSCAPING AND IRRIGATION DESIGN & ANALYSIS WILL BE PROVIDED ON THE LANDSCAPE & IRRIGATION PLANS. THE IRRIGATION SYSTEM MUST BE APPROVED AND INSTALLED PRIOR TO CERTIFICATE OF OCCUPANT.
 - ALL RADI AND DISTANCES ARE MEASURED TO THE BACK OF CURB UNLESS OTHERWISE NOTED.
 - ALL PAVEMENT SHALL BE PER TYPICAL PAVEMENT SECTION. REFER TO PAVEMENT PLAN FOR PAVEMENT DEPTHS.
 - THE CONTRACTOR SHALL PROMPTLY NOTIFY THE ENGINEER OF ANY DISCREPANCIES IN THESE PLANS, DRAWINGS AND SPECIFICATIONS.
 - IT IS THE RESPONSIBILITY OF THE CONTRACTOR TO COMPLY WITH ALL STATE AND FEDERAL REGULATIONS REGARDING CONSTRUCTION ACTIVITIES NEAR ENERGIZED OVERHEAD POWER LINES.
 - THE CONTRACTOR SHALL BE RESPONSIBLE FOR THE PROTECTION OF ALL EXISTING UTILITIES OR SERVICE LINES THAT ARE CROSSED OR EXPOSED DURING CONSTRUCTION OPERATIONS. WHERE EXISTING UTILITIES OR SERVICE LINES ARE CUT, BROKEN, OR DAMAGED, THE CONTRACTOR SHALL REPAIR OR REPLACE THE UTILITIES OR SERVICE LINE WITH THE SAME TYPE OF MATERIAL AND CONSTRUCTION OR BETTER. THIS MATERIAL AND WORK SHALL BE AT THE CONTRACTOR'S OWN EXPENSE.
 - A COPY OF THE APPROVED CONSTRUCTION PLANS MUST BE KEPT ON SITE AT ALL TIMES THROUGHOUT THE ENTIRE CONSTRUCTION OF THE PROJECT. CONTRACTOR SHALL MAINTAIN A SET OF REDLINE DRAWINGS, RECORDING AS-BUILT CONDITIONS DURING CONSTRUCTION.
 - ANY ADJACENT PROPERTY AND RIGHT-OF-WAY DISTURBED DURING CONSTRUCTION WILL BE RETURNED TO THEIR EXISTING CONDITION OR BETTER.
 - THE CONTRACTOR SHALL NOT CREATE A DIRT HURDANCE OR SAFETY HAZARD IN ANY STREET OR DRIVEWAY.
 - ADEQUATE DRAINAGE SHALL BE MAINTAINED AT ALL TIMES DURING CONSTRUCTION AND ANY DRAINAGE DITCH OR STRUCTURE DISTURBED DURING CONSTRUCTION SHALL BE RESTORED TO EXISTING CONDITIONS OR BETTER.
 - THE CONTRACTOR SHALL PROTECT ALL MONUMENTS, IRON PINS, AND PROPERTY CORNERS DURING CONSTRUCTION.
 - THE IRRIGATION SYSTEM WILL BE PROTECTED BY EITHER A PRESSURE VACUUM BREAKER, A REDUCED PRESSURE PRINCIPLE BACK FLOW DEVICE, OR A DOUBLE-CHECK BACK FLOW DEVICE, AN INSTALLED AS PER CITY ORDINANCE 2394.
 - ALL BACK FLOW DEVICES WILL BE INSTALLED AND TESTED UPON INSTALLATION.
 - THE CONTRACTOR MAY OBTAIN AN ELECTRONIC COPY OF THESE PLANS FOR CONSTRUCTION PURPOSES. THE ELECTRONIC FILE AND INFORMATION GENERATED, BY SCHULTZ ENGINEERING, LLC (SEL), FOR THIS PROJECT IS CONSIDERED BY SEL TO BE CONFIDENTIAL. WHEN ISSUED, IT'S USE IS INTENDED SOLELY FOR THE INDIVIDUAL OR ENTITY TO WHICH IT IS ADDRESSED. PERMISSION IS NOT GRANTED TO THE RECIPIENT FOR DISTRIBUTION OF THESE DOCUMENTS IN ANY FORM OR FASHION. THE RECIPIENT UNDERSTANDS THAT THIS DATA IS AUTHORIZED "AS IS" WITHOUT ANY WARRANTY AS TO IT PERFORMANCE, FREEDOM FROM ERRORS, OR AS TO ANY RESULTS GENERATED THROUGHOUT ITS USE. THE RECIPIENT ALSO UNDERSTANDS AND AGREES THAT SEL, UPON RELEASE OF SUCH DATA, IS NO LONGER RESPONSIBLE FOR THEIR USE OR MODIFICATION. THE USER AND RECIPIENT OF THE ELECTRONIC DATA ACCEPTS FULL RESPONSIBILITY AND LIABILITY FOR ANY CONSEQUENCES ARISING OUT OF THEIR USE.
 - CURB DETAILS REFER TO BRYAN - COLLEGE STATION STANDARD STREET DETAILS SHEET (FIGURE: ST, SHEET 1 OF 2).
- SITE SPECIFIC NOTES:**
- THE OWNER OF THE PROPERTY IS CARPOL FLOORING SERVICE LLC. THE SUBJECT PROPERTY IS THE RESERVE AT COTTONWOOD CREEK, BLOCK 1, LOT 1. PROPERTY IS ZONED RD-5.
 - THE TOTAL DISTURBED AREA FOR THIS PROJECT IS 1.77 ACRES (77299 SF).
 - THE SUBJECT TRACT DOES NOT LIE WITHIN THE 100 YEAR FLOODPLAIN ACCORDING TO FEMA FLOOD INSURANCE RATE MAPS FOR BRAZOS COUNTY, TEXAS AND INCORPORATED AREAS. COMMUNITY NO. 48002B, PANEL NO. 0195E, MAP NO. 480410195E, EFFECTIVE DATE: MAY 16, 2012.
 - PARKING LOT STRIPING OTHER THAN FIRE LANE STRIPING SHALL CONFORM TO TEXAS DEPARTMENT OF TRANSPORTATION (TxDOT) STANDARD SPECIFICATIONS FOR CONSTRUCTION OF HIGHWAYS, STREETS, AND BRIDGES: ITEM 666, TYPE 2 MARKING MATERIALS.
 - CONTOURS SHOWN ARE FROM FIELD SURVEY DATA.
 - THE CONTRACTOR SHALL BE RESPONSIBLE FOR THE CONTAINMENT AND PROPER DISPOSAL OF ALL LIQUID AND SOLID WASTE ASSOCIATED WITH THE CONSTRUCTION OF THIS PROJECT. THE CONTRACTOR SHALL USE ALL MEANS NECESSARY TO PREVENT THE OCCURRENCE OF WIND BLOWN LITTER FROM THE PROJECT SITE.
 - THE CONTRACTOR IS REQUIRED TO PROVIDE CONTAINMENT FOR WASTE, PRIOR TO AND DURING, DEMOLITION AND CONSTRUCTION. SOLID WASTE ROLL-OFF BOXES/METAL DUMPSTERS SHALL BE SUPPLIED BY THE CITY OR CITY PERMITTED CONTRACTOR(S) ONLY.
 - NORMAL DOMESTIC WASTEWATER IS ANTICIPATED TO BE DISCHARGED FROM THIS DEVELOPMENT.
 - ALL BACKFLOW DEVICES MUST BE INSTALLED AND TESTED UPON INSTALLATION AS PER CITY ORDINANCE.
 - THE IRRIGATION SYSTEM MUST BE PROTECTED BY EITHER AN ATMOSPHERIC OR A PRESSURE VACUUM BREAKER OR REDUCED PRESSURE PRINCIPLE BACK FLOW DEVICE AND INSTALLED AS PER CITY ORDINANCE.
 - 8" CONCRETE PAVEMENT TO BE PROVIDED FOR DUMPSTER LOCATIONS PER CITY OF BRYAN SPECIFICATIONS. DUMPSTER CONTAINMENT AREAS SHALL BE REINFORCED WITH #5 BARS AT 12" SPACING. THE PAD SHALL EXTEND AN ADDITIONAL 10' IN FRONT OF CONTAINMENT AREA.
 - ALL DEVICES, APPURTENANCES, APPLIANCES AND APPARATUS INTENDED TO SERVE SOME SPECIAL FUNCTION AND THAT CONNECTS TO THE WATER SUPPLY SYSTEM, SHALL BE PROVIDED WITH PROTECTION AGAINST BACKFLOW AND CONTAMINATION OF THE WATER SUPPLY.

PARKING ANALYSIS

EXISTING PARKING
42 EXISTING PARKING
3 SPACES ACCESSIBLE PARKING
45 SPACES PROVIDED

BENCHMARK INFORMATION

TM 1 N: 10229261.8482
 E: 3539841.1768
 ELEV: 355.34
 IRON ROD

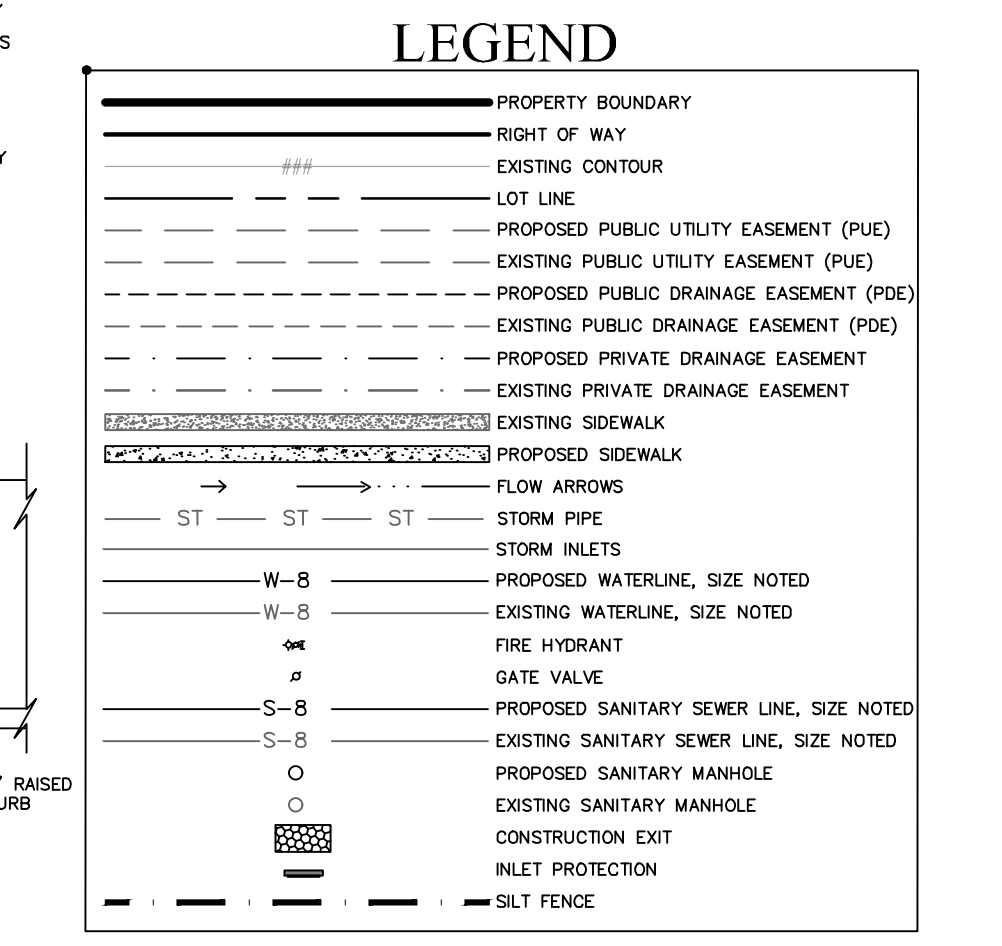

LINE TABLE

LINE #	LENGTH	DIRECTION
L12	66.24'	N71° 42' 18"E
L14	63.97'	N42° 58' 35"E
L15	49.41'	N54° 01' 37"E
L16	90.72'	S73° 11' 09"E
L17	13.65'	N85° 10' 25"W
L18	103.35'	N70° 46' 48"W

Curve Table

CURVE #	LENGTH	RADIUS	DELTA	TANGENT	CHORD	CHORD DIRECTION
C1	36.33'	200.00'	01°02'43"	18.22'	36.28'	N78°14'45"W

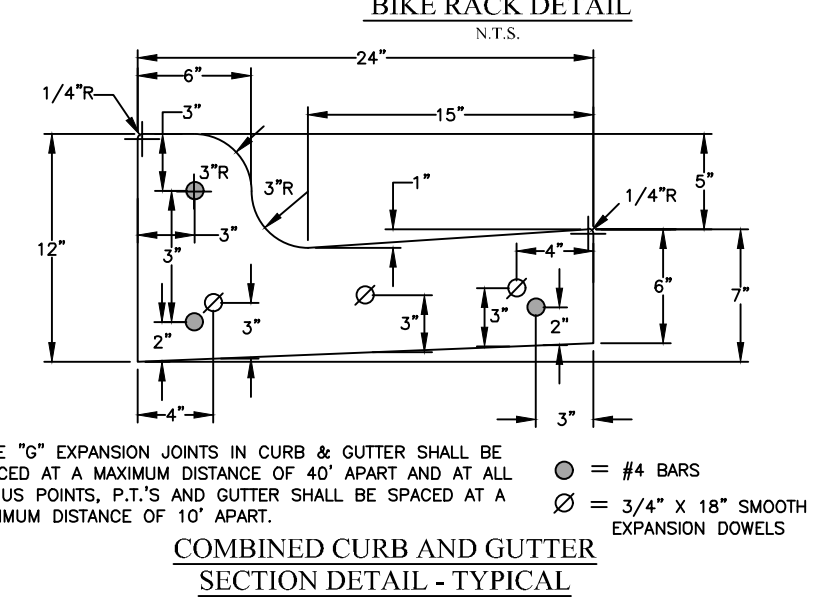
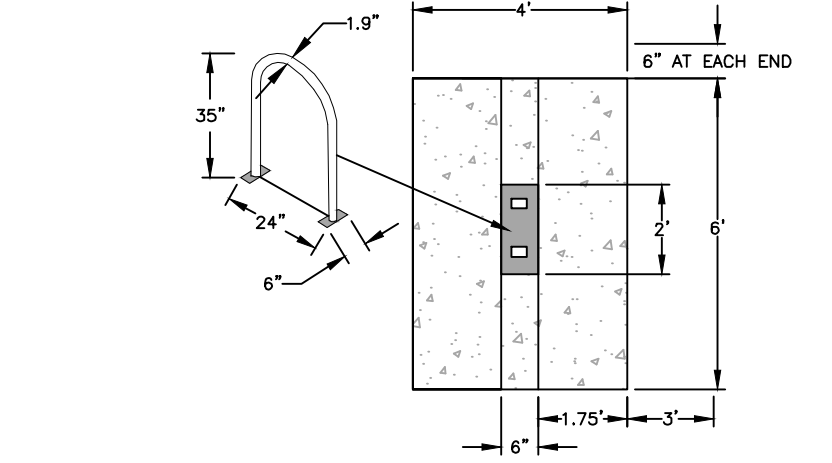
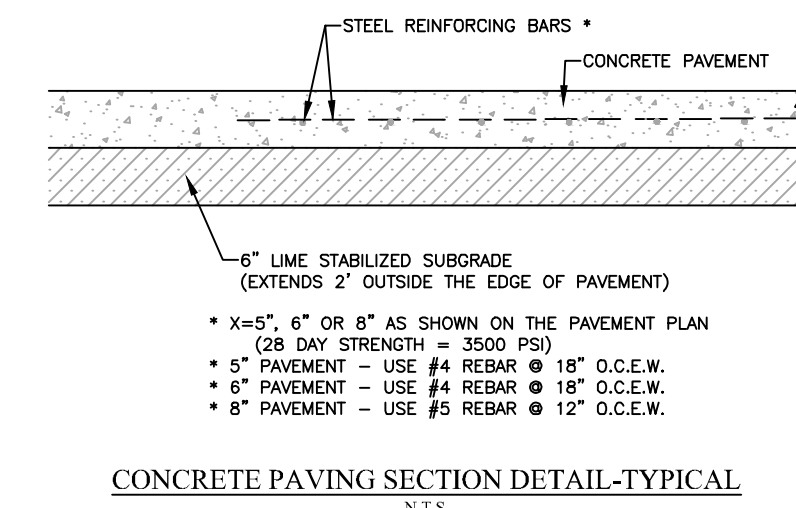
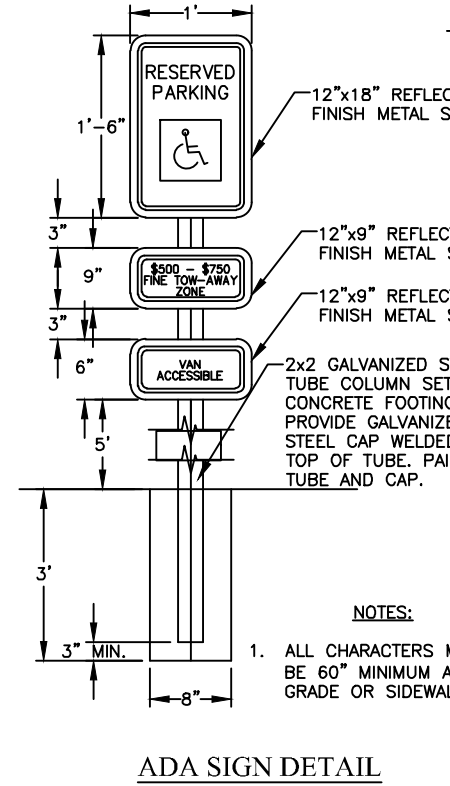
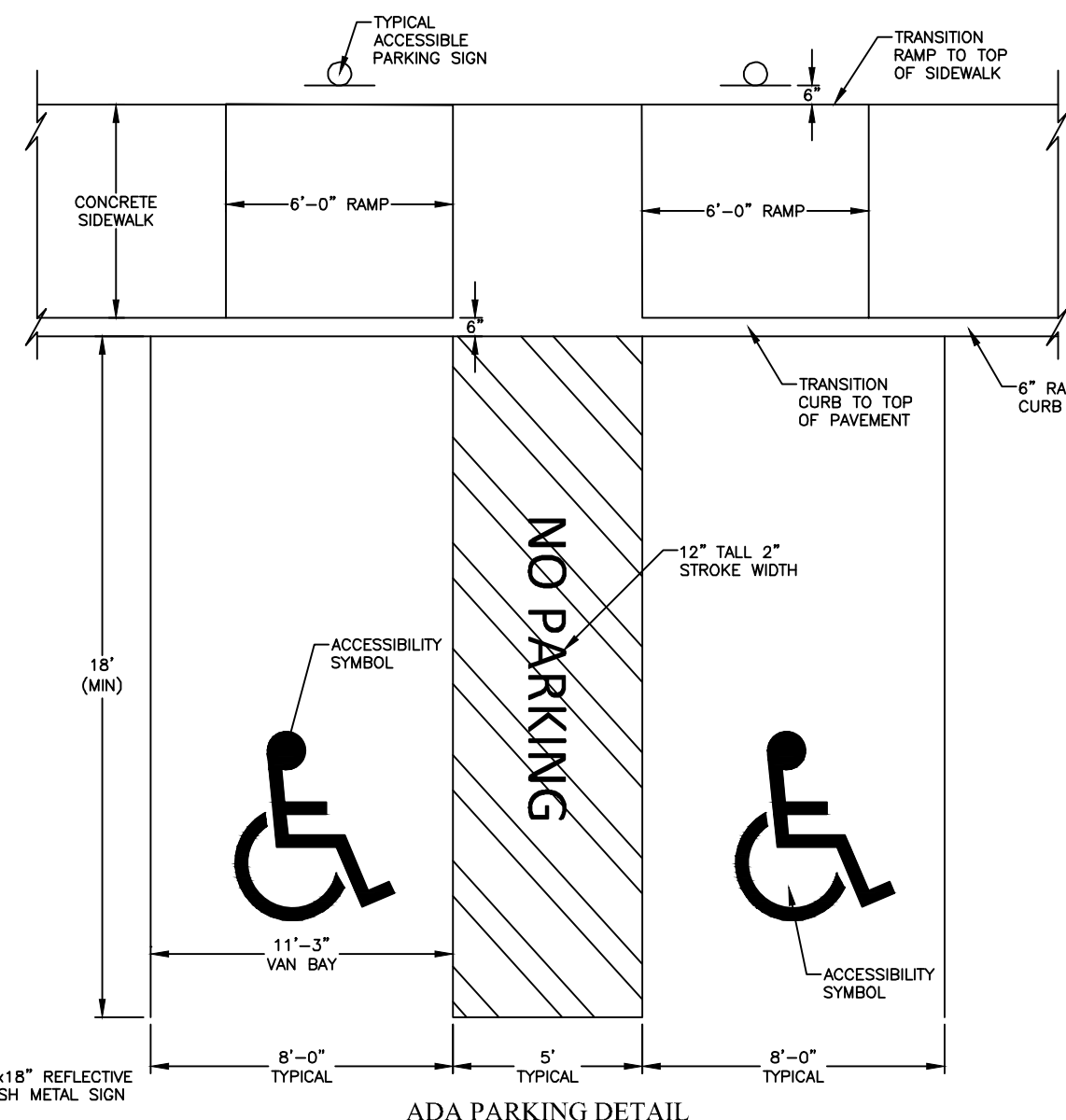

VICINITY MAP

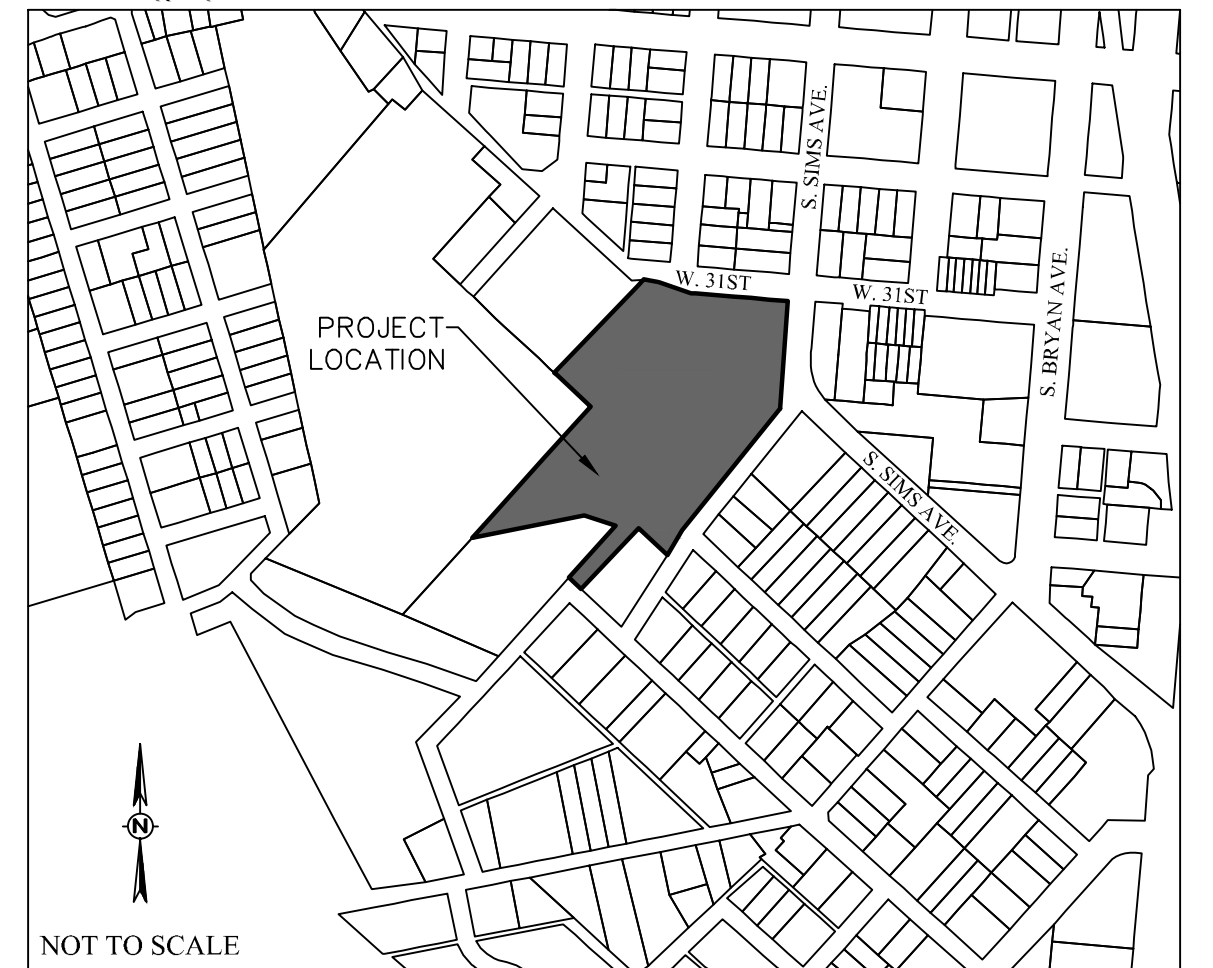

RESTORATION CHURCH
THE RESERVE AT COTTONWOOD CREEK

TOTAL DISTURBED AREA = 8.196 ACRES
 PHASE 1
 LOT 1R-1, BLOCK 1
 TOTAL AREA = 8.196 ACRES
 VOL. 18785, PG. 027
 SURVEY LEAGUE, A - 62
 BRYAN, BRAZOS COUNTY, TEXAS

SCALE: 1"=60' JULY 2024
 OWNER/DEVELOPER:
 RESTORATION CHURCH BRYAN
 307 N. TABOR ACENUE
 BRYAN, TX 77803

SURVEYOR:
 BRAD KERR, RPLS NO. 4502
 KERR SURVEYING, LLC
 409 N. TEXAS AVENUE
 BRYAN, TX 77803
 (979) 268-3195

ENGINEER:
 SCHULTZ ENGINEERING, LLC.
 PO BOX 11995
 COLLEGE STATION, TX 77842
 (979)764-3900

MARK	REVISION	BY	DATE

		911 Southwest Pkwy E. College Station, Texas 77840 979.764.3900 TPBE FIRM NO. 12327			
SURVEYED	DESIGNED	DRAWN	APPROVED	JOB NO.	DATE
KERR	DLD	DLD	JPS	23-105	JULY 2024

THIS DOCUMENT IS RELEASED FOR THE PURPOSE OF REVIEW ONLY UNDER THE AUTHORITY OF DEVEN L. DOYEN P.E., LICENSE NO. 109835, ON JULY 1, 2024. IT IS NOT TO BE USED FOR BIDDING OR CONSTRUCTION PURPOSES.

RESTORATION CHURCH
PHASE 1
 BRYAN, TX

SITE PLAN

SCALE	SHEET
VERTICAL: N/A	C1
HORIZONTAL: 1"=60'	
PLOTTING SCALE: 1:1	
FILE NAME: 23-105	